



ORDER-CODES:

KFLASH1

Overview

The Kentix alarm siren is used for acoustic and visual signaling in the event of an alarm. It is suitable for both indoor and outdoor installation (IP65 protection class).

The alarm siren is equipped with a 10 m long connection cable and is connected to the SystemPort of a suitable remote station via the supplied T-adapter. Suitable remote stations are SiteManager, AlarmManager and MultiSensor (Ethernet). The power supply is provided by the supplied power supply unit.

Safety instructions

Installation

Installation and commissioning may only be carried out by trained specialist personnel in accordance

with the instructions.

No modifications of any kind, other than those described in an appropriate manual, are permitted to Kentix GmbH products.

Certain levels of protection must be provided when installing Kentix equipment.

Observe the relevant regulations for installations in the respective environment.

Only operate the products within the defined temperature range.

The instructions should be passed on to the user by the person carrying out the installation.

Kentix accepts no liability for damage to the equipment or components resulting from incorrect installation. No liability is accepted for incorrectly programmed units.

Kentix shall not be liable in the event of malfunctions, damage to property or other damage.

Use of the products, transport and storage

Protect the device during transport, storage and operation from

Protect moisture, dirt and damage.

Battery powered products

Do not use products in potentially explosive atmospheres.

Only operate the products within the defined temperature range.

Installation and battery replacement may only be carried out by trained personnel in accordance with the instructions.

Do not charge, short circuit, open or heat batteries.

When inserting the batteries, pay attention to the correct polarity.

The devices must always be operated with the batteries intended for the product.

When changing batteries, always replace all batteries.

Dispose of old or used batteries properly.

Keep batteries out of the reach of children.

Maintenance

Kentix devices must be checked for functionality as part of annual maintenance.

Disposal

Electrical appliances and batteries must be disposed of separately from household waste.

Mounting and connection

The alarm siren is connected to the SystemPort of a suitable remote station. Suitable remote stations are SiteManager, AlarmManager and MultiSensor (Ethernet). The T-adapter is plugged in between the siren and the remote station. The third socket of the T-adapter is used to connect the power supply of the siren.

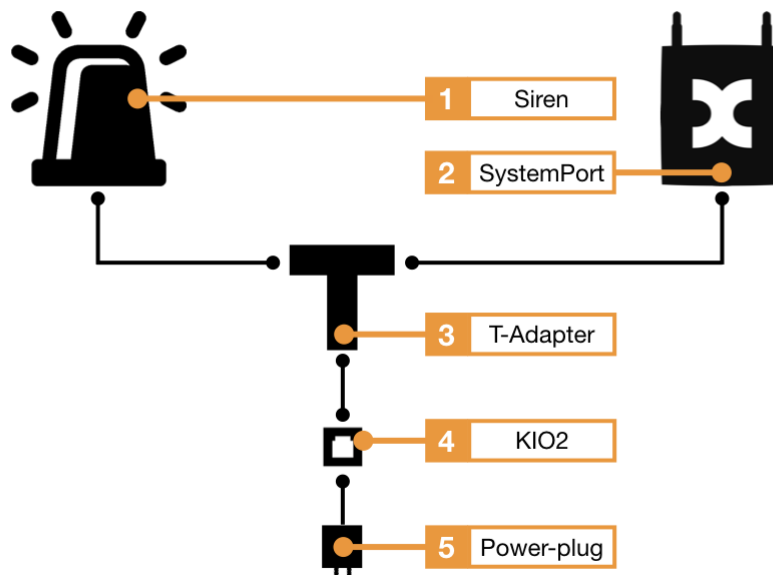

1. Alarm siren
2. Remote station with system port (TYPE-A)
3. T-adapter
4. Power adapter KIO2
5. Power supply 24VDC

ATTENTION! The siren must not be operated on devices (SmartPDU) with the Kentix TYPE-B system port.

Configuration with KentixONE

The configuration is done via web browser (HTTPS) using the already integrated KentixONE software. Depending on the operating mode (Main or Satellite) of the device, the configuration takes place on the device itself (operating mode: Main), or on a central instance such as the SiteManager or AlarmManager (operating mode: Satellite).

All information about the software is available in the [KentixONE](#) section and the related documentation.

Before you start the configuration, make sure that the software is up to date on all network-enabled Kentix devices. The version status must be the same on all devices.

You can download the latest software here: [KentixONE](#)